

Opções em

GANCHEIRAS PARA CARTELADOS/BLISTERS

AS1501 - GRANDE (20CM)

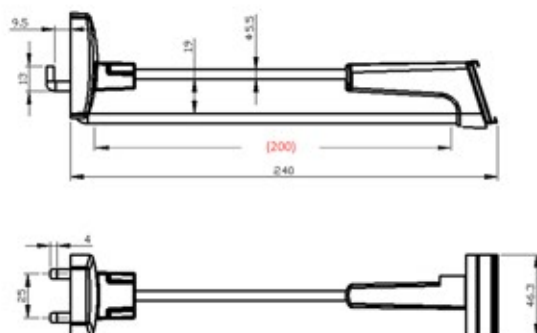
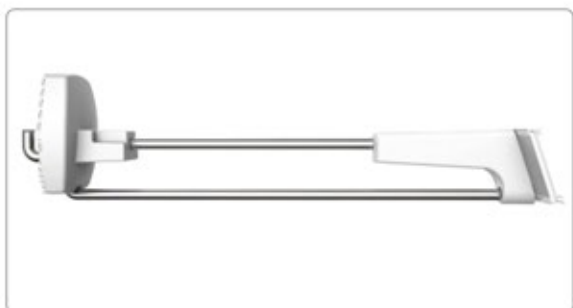

AS1502 - MÉDIA (15CM)

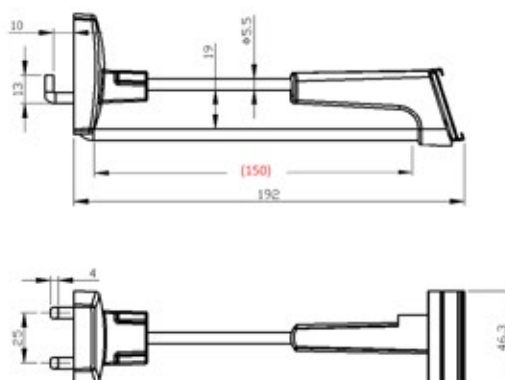

AS1500 - PEQUENA (12CM)

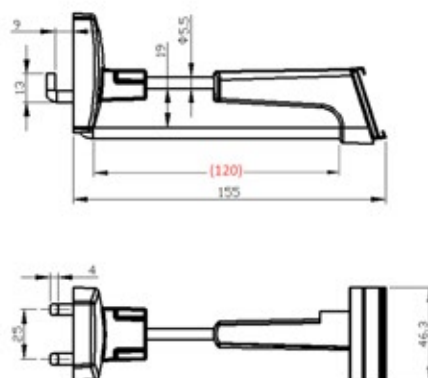

CARACTERÍSTICAS

Material: ABS + Aço Inoxidável

Cor: Branca

Tamanho: 235x60x44mm

Comprimentos: 240/185/145mm

 Confira o vídeo com o passo-a-passo de instalação

<https://www.youtube.com/watch?v=keX2FQqRdh0>

VISTA TRASEIRA



ACOMPANHA CHAVE MAGNÉTICA

